

SmallRig

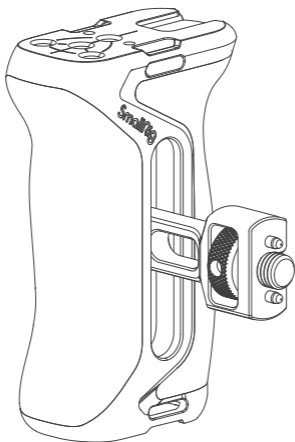

ARRI Locating Side Handle

阿莱侧手柄

Operating Instruction | 操作指引

Thank you for purchasing SmallRig's product.

感谢您购买 SmallRig 产品。

Installation Instruction

安装步骤

1

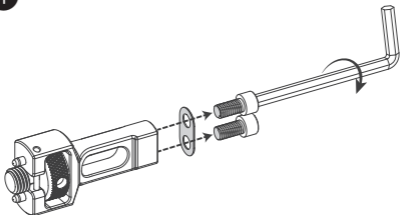

2

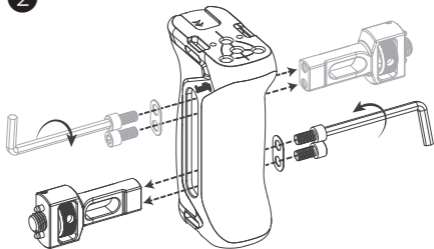

3

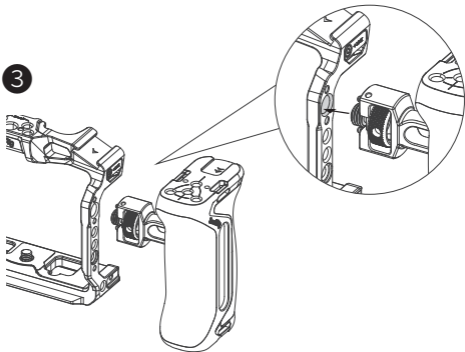

4

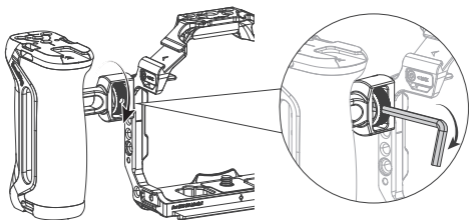

Service & Warranty

Please keep your original receipt and guarantee card. Be sure the dealer has written on it the date of purchase and SN of the product. These are required for warranty service.

After-sale Warranty Terms

SmallRig products are entitled to warranty services as of the date of payment.

- Electronic products (except V mount battery): 1-year warranty.
- V mount battery: 2-year warranty.
- Non-electronic products: 2-year warranty.

Note: In case of any conflict between our warranty period policy and applicable laws and regulations of the country / region where the products are sold, the latter shall prevail.

This Warranty Does Not Cover

1. If users fail to adhere to the "Operating Instruction" or any "Warnings" stated in the user manual, resulting in a quality failure, it falls outside the scope of warranty coverage.
2. The product identification or SN label is removed or defaced in any way.
3. Product damage caused by problems not attributable to the quality of the products such as improper use of the products.
4. Product damage caused by unauthorized modification, disassembly, repair and other acts.
5. Product damage caused by fires, floods, lightning and other force majeure factors.

Warranty Mode

- For the products within the scope of warranty, SmallRig will repair or replace them on the basis of specific failures; the repaired / replaced products / parts are entitled to the remaining part of the original warranty period.

Contact Information

- You're advised to contact the online customer service personnel of corresponding shopping platform and submit a repair service application.
- You may also apply for repair service through SmallRig's service email.

Service Email: support@smallrig.com

保修条款

请保留您的原始购买单据及保修卡,同时包含您的购买日期、产品序列号等,这些资料质保服务时均需要提供。

售后质保条款

SmallRig产品自下单付款之日起享有质保服务。

- 电子产品(除V口电池): 1年质保。
- V口电池: 2年质保。
- 非电子产品: 2年质保。

注:若销售地国家或地区的适用法律法规有冲突的,以销售地国家或地区有关质保期的法律法规为准。

质保无效说明

1. 当用户违反操作指引或用户手册中“重要提示”任何一条导致的质量失效,不在质保范围内。
2. 产品序列号标识已经被撕毁或无法辨识,不在质保范围。
3. 产品使用不当等非产品本身质量问题,而造成的产品损坏,不在质保范围。
4. 非官方指导的私自改装、拆解、维修等行为而造成的损坏,不在质保范围。
5. 因火灾、水灾、雷击等不可抗力造成的产品损坏,不在质保范围。

维修方式

·属于质保范围的,SmallRig根据产品具体的故障对产品进行维修或更换;维修后的产品/部件享受原有保修期的剩余时长。

联系方式

- 建议您优先前往相应购买平台联系在线客服,提出产品维修申请。
 - 您也可以通过 SmallRig 服务邮箱申请维修服务。
- 服务邮箱: support@smallrig.com

EC	REP	Prolinx GmbH Brehmstr.56,40239 Duesseldorf Germany eu@eulinx.eu
----	-----	---

UK	REP	Prolinx Global LTD 27 Old Gloucester Street London, WC1N3AX, UK eu@eulinx.eu
----	-----	--

Guarantee Card / 保修卡

ID No. ID 编号	
Item Name 产品名称	
Purchase Date 购买日期	
User Name 用户姓名	
Mobile 用户电话	
Address 用户地址	
Receipt 购买单据	

Manufacturer: Shenzhen Leqi Innovation Co., Ltd.

制造商: 深圳市乐其创新股份有限公司

Add: Rooms 103, 501 and 601, Building 5, Fenghe Industrial Park, Nos. 1301-50
Guanguang Road, Longhua District, Shenzhen, Guangdong, China.

地址: 中国广东省深圳市龙华区观澜街道新澜社区观光路1301-50号丰和工业园厂房
5 栋 103、501、601

Consignor: Shenzhen LC Co., Ltd.

委托商: 深圳市乐长科技有限公司

Add: Rooms 602, Building 5, Fenghe Industrial Park, No. 1301-50 Guanguang
Road, Xinlan Community, Guanlan Street, Longhua District, Shenzhen,
Guangdong, China.

地址: 中国广东省深圳市龙华区观澜街道新澜社区观光路1301-50号丰和工业园厂房
5 栋 602

执行标准: GB/T 26572-2011

CE RoHS



FR
LE TRI
+ FACILE



Boite 1



Papier 5



BAC DE TRI

Séparez les éléments avant de trier

LQ-P1367-18